

# MSite Touch

## Technical Specification

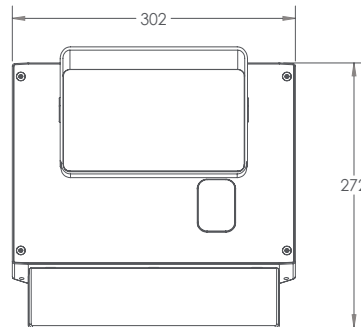

**Front**

272mm x 302mm

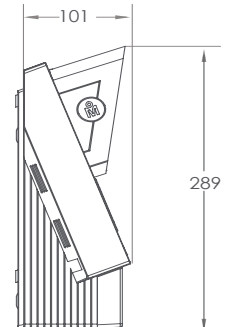

**Side**

280mm x 101mm

<b>2-way Interaction</b>	Displays messages to the user and accepts input by the user via its touch screen.
<b>Construction Ready</b>	Designed specifically to work with dirty/poor quality fingerprints.
<b>Access Control Mode</b>	Outputs Wiegand data for integration with access control systems.
<b>Freestanding Option Available</b>	MSite Touch can be wall or desk mounted.
<b>Time &amp; Attendance Mode</b>	MSite Touch can be re-configured ( <i>via the MSite website</i> ) to ask users if they are arriving or leaving before they complete their transaction.
<b>Pin Entry</b>	Allow certain users who are unable to present a fingerprint to enter a PIN number for access.
<b>Identification Speed</b>	<1 second
<b>Dimensions</b>	302, 289, 101mm
<b>Voltage</b>	12vDC
<b>Weight</b>	2.6kg
<b>Operating Temperature</b>	-20°C to 40°C
<b>Language Support</b>	English*

### MSite Touch Specification:

- If located outdoors, then the site needs to erect a shelter over the unit.
- If located indoor, 3 pin with step down can be used.
- If located outdoors 240v isolated fused spur at unit location.
- Sarel Enclosure (300mm x 200mm) to be located within proximity to the MSite touch station.

### Additional Information

#### Disclaimer

Other languages available on request. All measurements are in mm.