

# MSite Touch



## Biometric Verification

Biometrics verify operative identity against their unique MSite profile to authorise site access



## Real Time Data

Site teams and head offices have total visibility of exactly who is on site at any point in time



## Time & Attendance

Attendance data can that drives productivity, reviewing actual hours worked vs planned.



[Learn More >](#)

MSite Touch recognises your fingerprint upon entry giving site access to only you. Using biometrics, this method of contactless sign in can't be replicated, is swift and secure.



## Pin Options

There is a PIN fallback option for site visitors or operatives who cannot utilise biometric options.



## Suitable for Remote Sites

The 4G version is ideal for remote site setups, or sites with no fixed perimeter, as you can easily move the device from one location to another.



+44 (0) 333 456 2001

[Book a Demo](#)



[MSite.com](#)

# MSite Touch

## Technical Specification

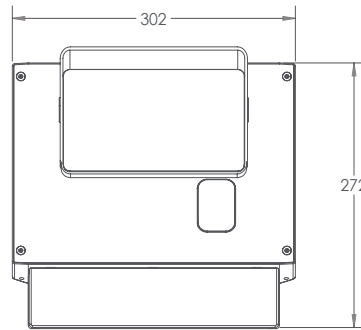

**Front**

272mm x 302mm

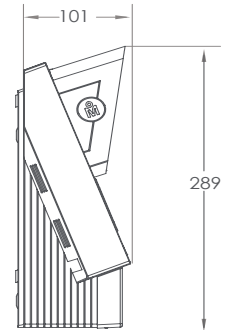

**Side**

280mm x 101mm

<b>2-way Interaction</b>	Displays messages to the user and accepts input by the user via its touch screen.
<b>Construction Ready</b>	Designed specifically to work with dirty/poor quality fingerprints.
<b>Access Control Mode</b>	Outputs Wiegand data for integration with access control systems.
<b>Freestanding Option Available</b>	MSite Fingerprint Reader can be wall or desk mounted.
<b>Time &amp; Attendance Mode</b>	MSite Touch can be re-configured ( <i>via the MSite website</i> ) to ask users if they are arriving or leaving before they complete their transaction.
<b>Pin Entry</b>	Allow certain users who are unable to present a fingerprint to enter a PIN number for access.
<b>Identification Speed</b>	<1 second
<b>Dimensions</b>	302, 289, 101mm
<b>Voltage</b>	12vDC
<b>Weight</b>	2.6kg
<b>Operating Temperature</b>	-20°C to 40°C
<b>Language Support</b>	English*

<b>MSite Touch Specification:</b>	<ul style="list-style-type: none"> <li>• If located outdoors, then the site needs to erect a shelter over the unit.</li> <li>• If located indoor, 3 pin with step down can be used.</li> <li>• If located outdoors 240v isolated fused spur at unit location.</li> <li>• Sarel Enclosure (300mm x 200mm) to be located within proximity to the MSite touch station.</li> </ul>
-----------------------------------	--------------------------------------------------------------------------------------------------------------------------------------------------------------------------------------------------------------------------------------------------------------------------------------------------------------------------------------------------------------------------------

<b>Additional Information</b>	<p><b>Disclaimer</b></p> <p>Other languages available on request. All measurements are in mm.</p>
-------------------------------	---------------------------------------------------------------------------------------------------